

# POLAR 80 VACUUM PACKAGING MACHINE



## DESCRIPTION:

The robust, stainless steel Polar 80 vacuum packaging machine is standard equipped with a Busch vacuum pump. This floor model complies with CE standards.



## FEATURES:

- Standard with 2 seal bars: 760 mm (front), 510 mm (right)
- Other seal bar configurations available for free (front-back, left-right)
- Standard double seal (two wires). Optional without extra costs: Cut off or Wide seal (10 mm)
- Silicone holders easily removable for cleaning and maintenance purposes
- Pump capacity: 100 m<sup>3</sup>/h Busch vacuum pump
- Pump maintenance and cleaning program
- Machine cycle: 15-40 sec
- Standard Soft Air to protect the product and vacuum bag
- Standard Digital control with 10 program memory and Time control
- Flat work plate
- Comes with insert plates for a faster cycle and product adjustment
- Stainless steel exterior
- IP-65 Classification

## OPTIONS:

- 3 seal bars (left-front-right)
- 1-2 Cut off/Bi-active seal
- Sensor control, Advanced Control System (ACS)
- Liquid control
- Gas flush (including pressed air connection)
- Preparation for external pump
- **New: Extra high contra bar**

## ACCESSORIES:

- Zebra ZD410 thermal label printer (only in combination with ACS)
- Inclined insert plate (for vacuum packing liquids and powders)
- Service kit for standard maintenance

## SEAL BAR CONFIGURATION:

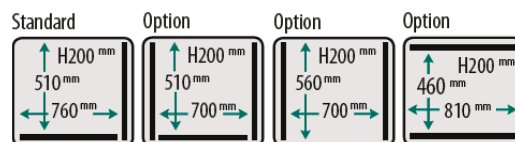

## Sales and Service Support

**Phone:**  
(07) 3806 5972

**Email:**  
sales@vacpac.com.au  
service@vacpac.com.au

## Visit our Showroom

Unit 3, 14-16 Cairns Street,  
Loganholme QLD, Australia 4129

# POLAR 80 VACUUM PACKAGING MACHINE



## DIMENSIONS (IN MM)

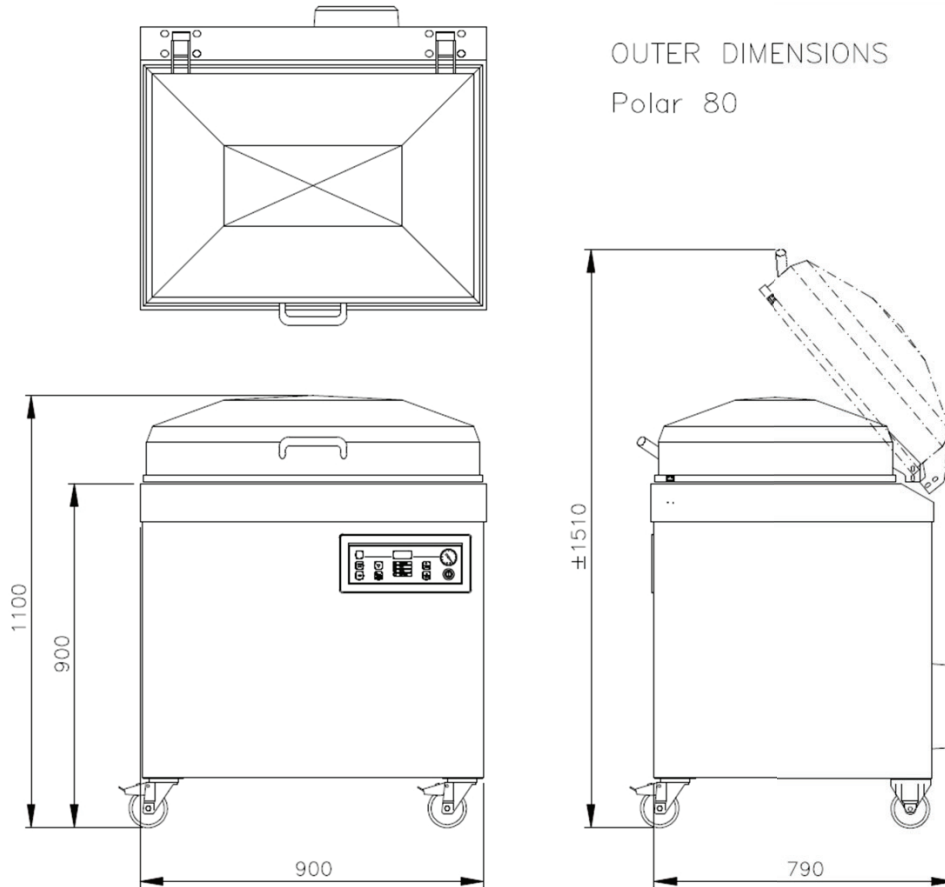

OUTER DIMENSIONS  
Polar 80

Model	Dimensions (mm)		Voltage* (Hz)	Pump capacity (m <sup>3</sup> /h)	Power (kW)	Weight (kg)
	Chamber (usable space) L x W x H	Machine L x W x H				
Polar 80	510 x 760 x 200	790 x 900 x 1100	400V-3-50	100	3,0-5,0	248

\* Other voltages available

VACUUM PACKAGING MACHINE — POLAR 80 — SPEC SHEET



### Sales and Service Support

**Phone:**  
(07) 3806 5972

**Email:**  
sales@vacpac.com.au  
service@vacpac.com.au

### Visit our Showroom

Unit 3, 14-16 Cairns Street,  
Loganholme QLD, Australia  
4129